

中央空调工程设计常见问题

1

2

4

40m

5m

22

1

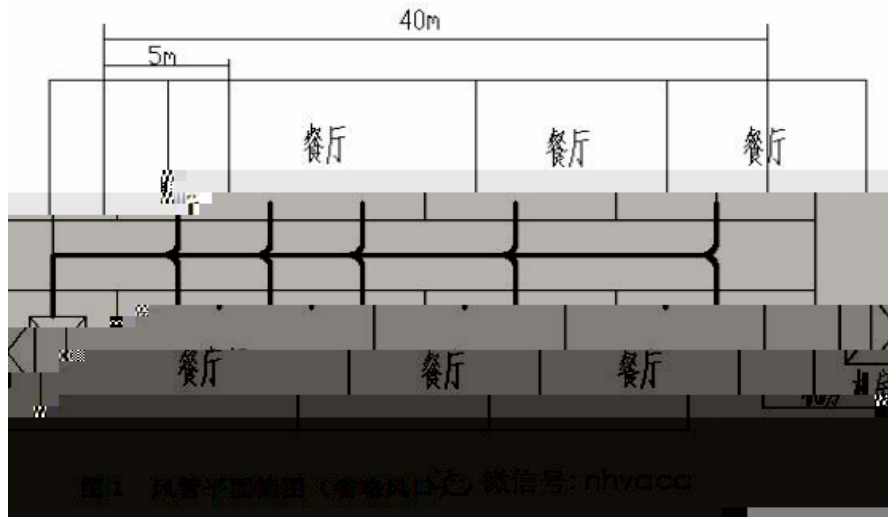

2



图2 吊顶回风的弊病

微信号: nhvacd

3

3 4

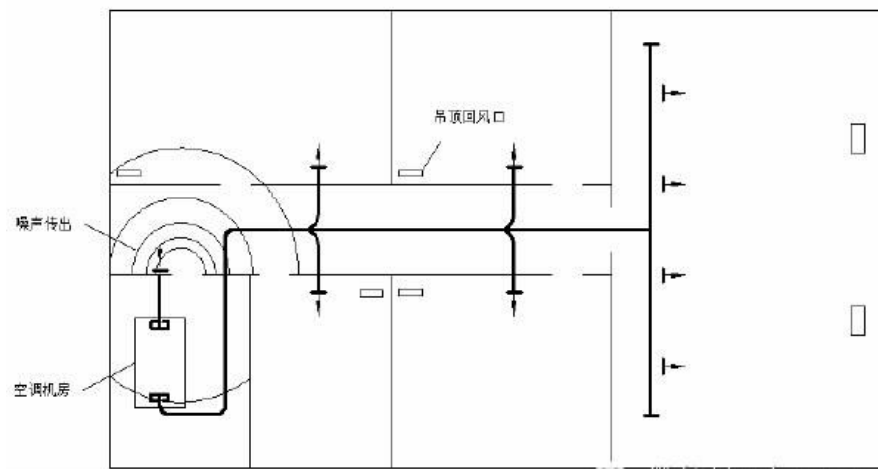
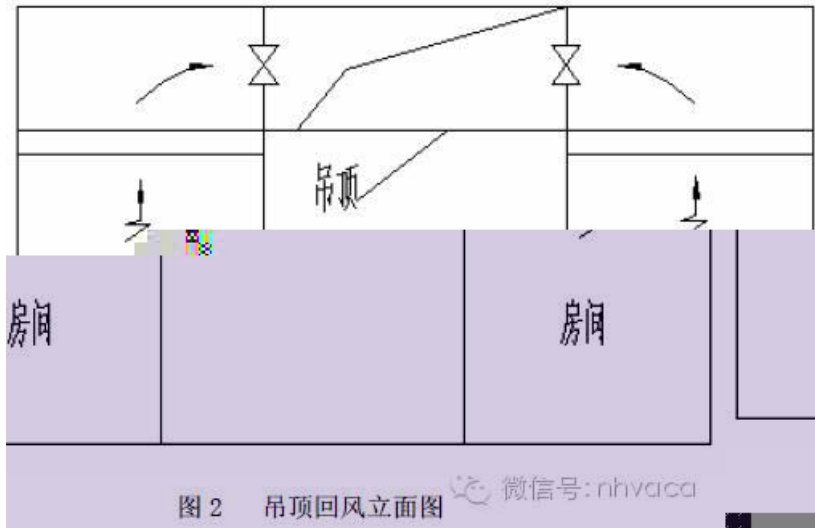

2

—

0. 981MPa 1. 715 MPa 2. 058MPa

2 MPa

4

1 4 5

2 6 3

7 /12

8 8.5 13 13.5

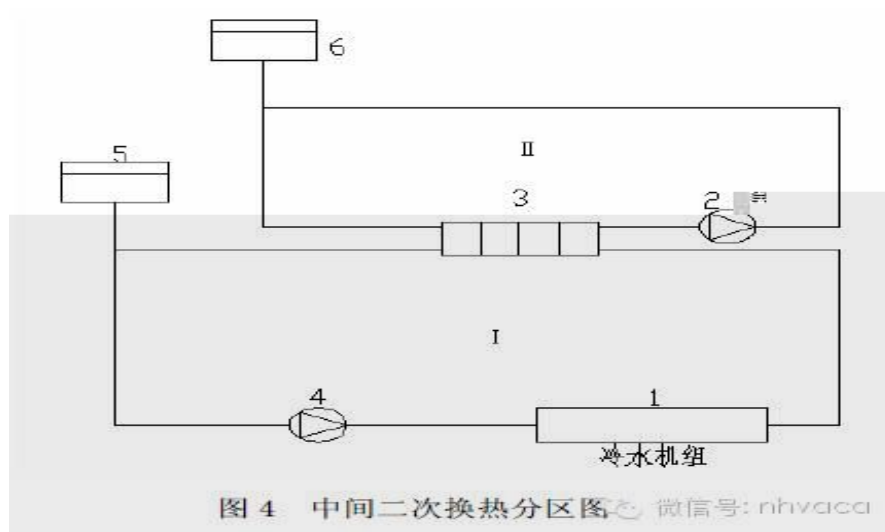

a

5



图 5 上下分别设置冷源示意图 微信号: nhvacca

b

6

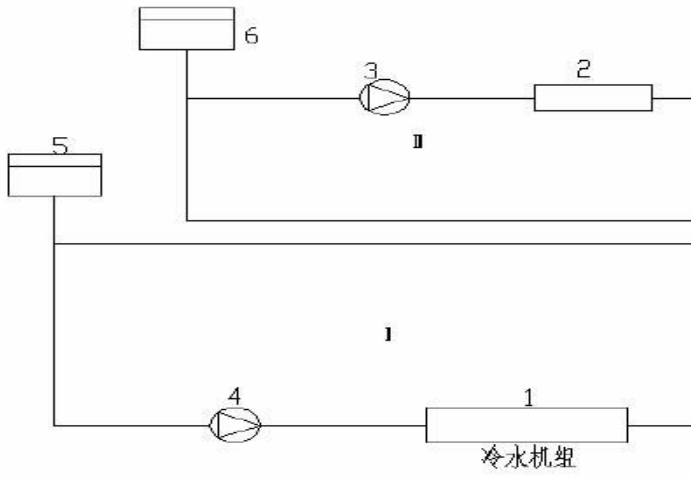

图 6 分设冷源分区示意图 微信号: nhvacca

c

3

7

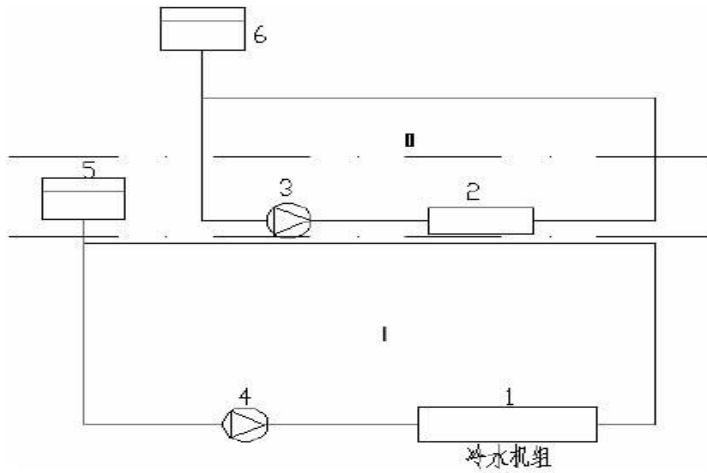
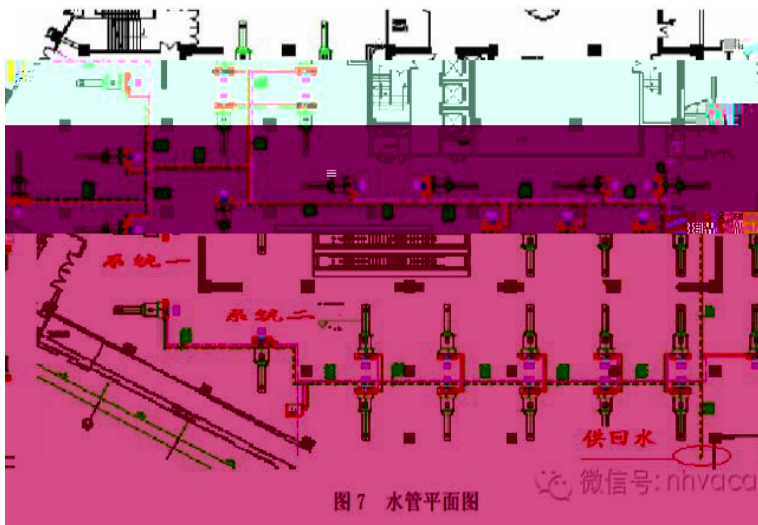

1

2

3

4

12 6

GW-R300W2/B 5 GW-R860W6/A 1 GW-R900W6/A

1

2m

1.5m



图 1

GW-R860W6/A GW-R900W6/A

1

2

GMWL-R860W6/A-N1 GMWL-R900W6/A-N1

a

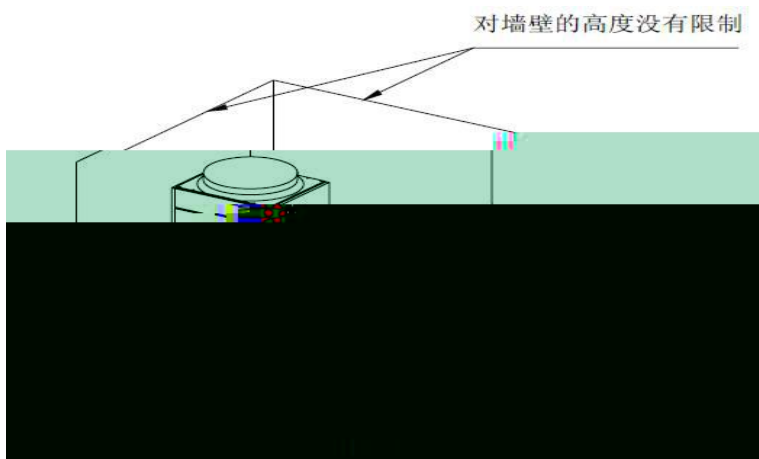

b

1

2

3

4

1
0.01
2
3
4
6

t=26

=50%

14.8

:

1

2 3

t=4.5

t=3.6

t=2.0

2

5mm

1

2

1

2